

Analog Voltage(0-5V & 0-10V) Stepper Motor Driver User Manual

Table of Contents

- I. Product Overview
- II. Product Schematic Diagram
- III. Interface Definition and Wiring Instructions
 1. Motor Interface
 2. Power and Control Signal Interface
- IV. Signal Lights
- V. Function Description
 1. Motor Drive Function
 2. Enable Control (ENA)
 3. Direction Control (DIR)
 4. Stepping Drive (STP)
 5. Gear Adjustment (VCC)
- VI. Software Usage Instructions
 1. Page Function Description
 2. Usage Precautions
- VII. Usage Precautions
 1. Power Wiring
 2. Motor Wiring
 3. Signal Control
 4. Heat Dissipation and Protection
 5. Software Flashing Configuration Notes
- VIII. Troubleshooting

I. Product Overview

This stepper motor driver is a driver module designed specifically for two-phase four-wire stepper motors. It realizes motor enable control, direction control, stepping drive, and power supply functions. It is suitable for small automation equipment, 3D printers, numerical control devices, and other scenarios.

II. Product Schematic Diagram

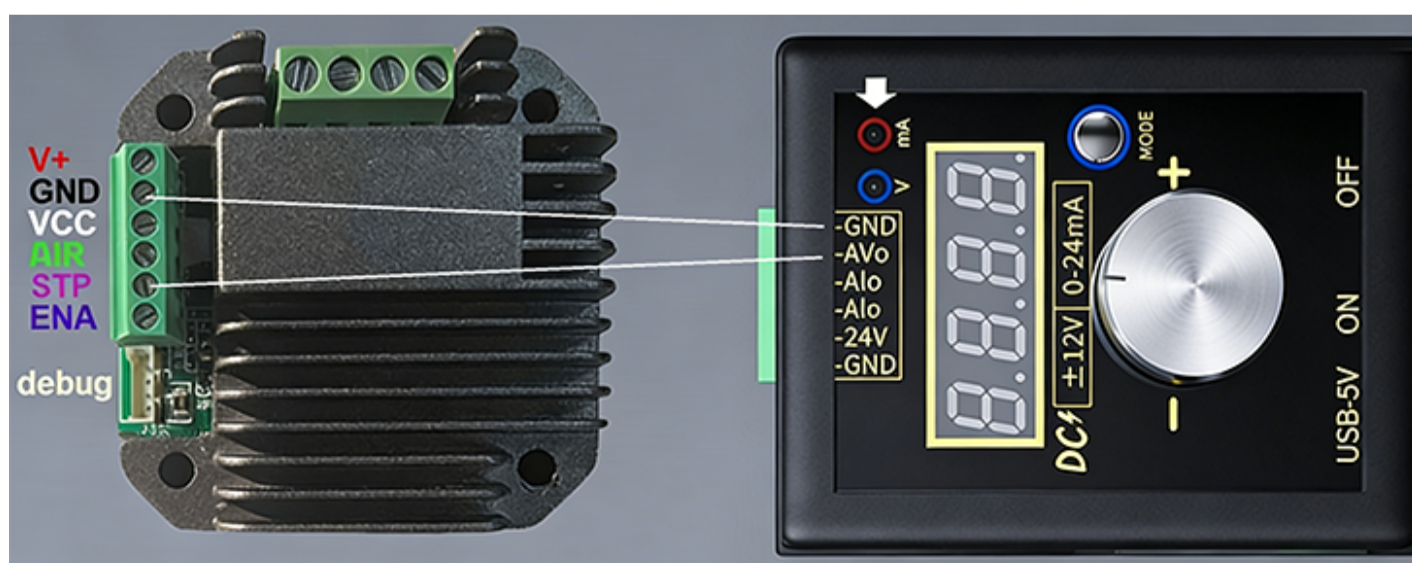

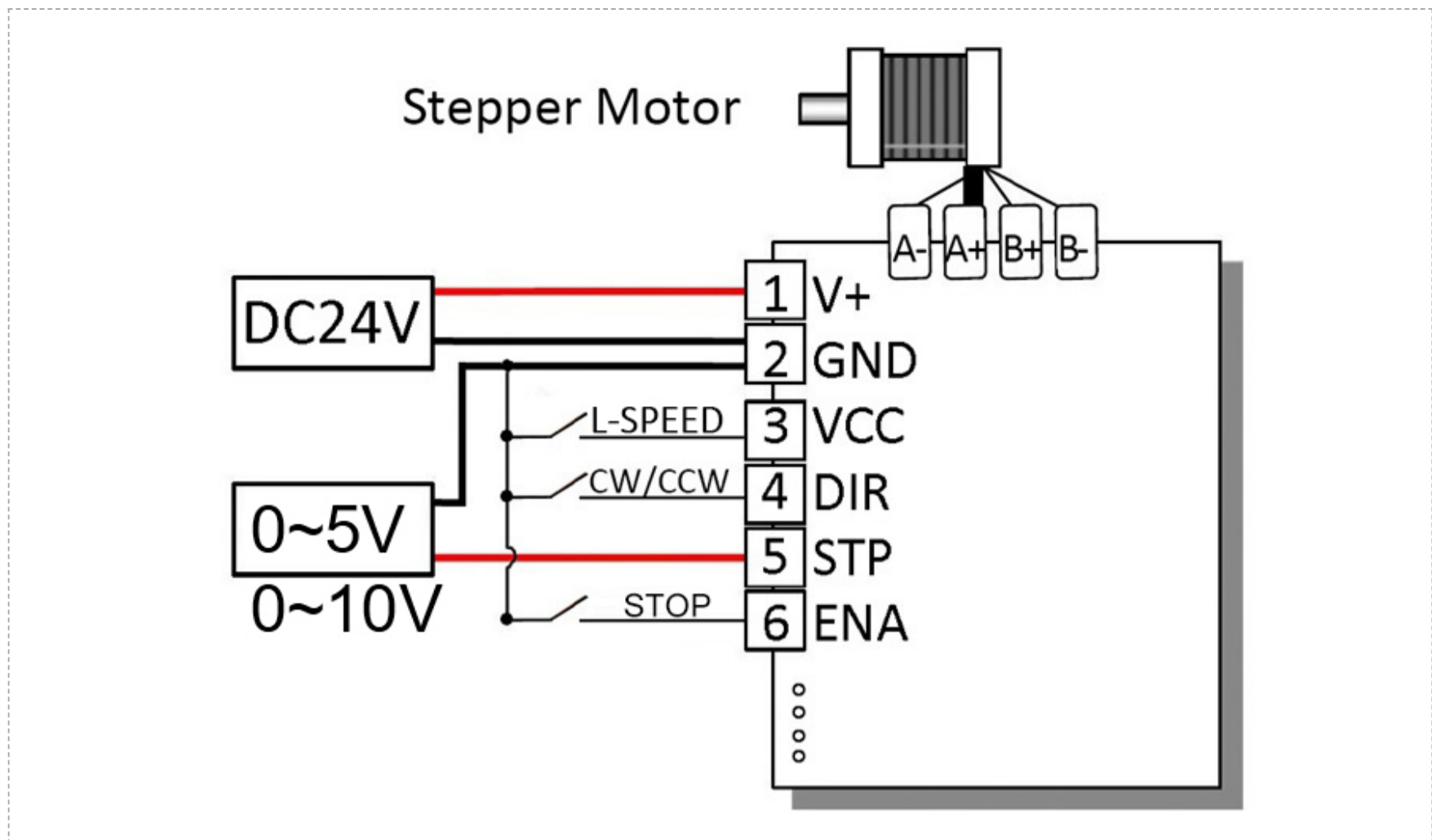

III. Interface Definition and Wiring Instructions

1. Motor Interface

Pin Label	Function Description	Wiring Object
A+	Stepper Motor Phase A Positive Terminal	Stepper Motor Phase A Coil Positive Electrode
A-	Stepper Motor Phase A Negative Terminal	Stepper Motor Phase A Coil Negative Electrode
B+	Stepper Motor Phase B Positive Terminal	Stepper Motor Phase B Coil Positive Electrode
B-	Stepper Motor Phase B Negative Terminal	Stepper Motor Phase B Coil Negative Electrode

Note: A+/A- and B+/B- must correspond to the two-phase coils of the motor respectively; they cannot be cross-connected or mixed.

2. Power and Control Signal Interface

Pin Label	Function Description	Wiring Object	Electrical Characteristics
24V	24V DC Power Positive Input	External 24V DC Power Positive Electrode	Rated Input Voltage: DC 24V (9-30V) Typical Value: 24V
GND	Power Ground / Signal Ground	External Power Negative Electrode, Control Signal Ground	-
VCC	Switch to Low Speed	Floating: High Speed; GND: Low Speed	Vmax = 5.5V, Vmin = 2.1V Typical Value: 5V
DIR	Motor Direction Control Signal Input	Floating: CW; GND: CCW	Vmax = 5.5V, Vmin = 2.1V Typical Value: 5V
STP	Step Voltage Signal Input	Analog Voltage Signal: 0-5V or 0-10V	Voltage Range 0-15V (Max voltage customizable via software within 15V)
ENA	Enable Control Signal Input	Floating: Enable; GND: disable	Vmax = 5.5V, Vmin = 2.1V Typical Value: 5V

Warning: VCC, DIR, STP, ENA have a maximum source current of 20mA and a maximum sink current of 50mA. Control signals must share a common ground with the driver.

IV. Signal Lights

Light Display	Function Description	Solution
Red, Green, Blue Alternating Flash	Chip configuration not written	Write configuration software program via the flashing port
Red Light Fast Flash	Low Voltage or High Voltage Alarm	Adjust power supply voltage to within the specified range
Green Light Fast Flash	High Temperature Alarm	Add heat dissipation measures
Blue Light Fast Flash	Motor Overcurrent Alarm	Check for motor short circuit or other overcurrent conditions after power off
White Light Slow Flash	Motor Normal Operation	-

V. Function Description

1. Stepper Motor Driver Function

Connects to a two-phase four-wire motor via A+/A-, B+/B- interfaces. The internal drive circuit converts control signals into coil current to achieve stepping.

2. Enable Control (ENA)

High/Low level. The motor working state can be configured in software, allowing for motor free state (energy saving / emergency stop).

3. Direction Control (DIR)

Changes the level to switch the motor rotation direction.

4. Stepping Driver (STP)

Receives analog voltage signal. The specific voltage corresponding to rotation speed is set in the software.

5. Switch to Low speed range(VCC)

Switch to the low speed range, default high speed range when floating, Must be set when the motor is stopped.

VI. Software Usage Instructions

Voltage Type
User has configured.

中文/English

ImportConfig

SaveConfig

CommonConfig

NormalConfig

Download

FactoryDataReset

Power-on default operation	<input checked="" type="checkbox"/>		Motor running current (Determines Motor Torque)	<input type="text" value="1.00"/>	Range: 0-2A
Subdivision	<input type="text" value="16"/>		Standby Current	<input type="text" value="16/32"/>	0=1/32...31=32/32
Upper and lower voltage limits(V)	<input type="text" value="0"/>	<input type="text" value="5"/>			Range: 0~15V
Minimum Speed (RPM)	<input type="text" value="0"/>	Maximum speed in low gear (RPM)	<input type="text" value="150"/>	High-end maximum speed(RPM)	<input type="text" value="1000"/>
Acceleration time(ms)	<input type="text" value="1000"/>	Deceleration time(ms)	<input type="text" value="1000"/>		
SPEED_MODE (RPM)	<input type="text" value="60"/>				

1. Page Function Description

- **Power-on Default Run Switch:** When turned on, the motor automatically rotates upon power-on and valid enable signal; when turned off, ENA must be connected to GND to run.
- **Motor Running Current Value:** Determines torque. Higher values result in higher heat generation.
- **Subdivision Value Setting:** Options include Full step, 2, 4, 8, 16, 32, 64, 128, 256.
- **Standby Current Value:** Standby Current = Running Current × (1/32 ~ 32/32).
- **Voltage Upper/Lower Limits:** Sets the adjustable voltage range 0-15V.
- **Minimum Speed:** Motor speed corresponding to the minimum voltage.
- **Low Gear Maximum Speed:** Maximum adjustable speed in low gear mode.
- **High Gear Maximum Speed:** Maximum adjustable speed in high gear mode.
- **Acceleration Time:** Time from 0 to maximum speed. Should not be too short when rotation speed is high.
- **Deceleration Time:** Time to decelerate from maximum speed to 0. Similarly, should not be too short.

2. Usage Precautions

- If the prompt "Device Type Mismatch" appears, please close the software and reopen it.
- Prompt "Missing Parameters or Parameter Error": Possible cause is configuration file not imported or unstable voltage. Import configuration file and re-download.
- Software adjustments require power cycling to take effect.
- **Danger:** During flashing, only one power source (either flashing port power or motor 24V power) can be used, otherwise the chip will burn. If using motor 24V power for flashing, disconnect the power line of the flashing port, ensuring the ground line remains connected.

VII. Usage Precautions

1. Power Wiring

- Strictly prohibit reversing the positive and negative poles of the 24V power supply, otherwise the controller will burn.
- The power supply must reserve at least 30% power margin.
- Power ground (GND) must be reliably connected to the control signal ground.

2. Motor Wiring

- Avoid short circuits in motor coils, otherwise the drive circuit will be damaged.

3. Signal Control

- Voltage control signals must share a common ground with the controller and must not exceed the maximum voltage to avoid burning.

4. Heat Dissipation and Protection

- Ensure good ventilation and heat dissipation. It is recommended to connect a fuse in series at the 24V input end.

5. Software Flashing Configuration Notes

- Strictly observe the single power supply principle during flashing. Refer to the software chapter for details.

VIII. Troubleshooting

Fault Phenomenon	Possible Cause	Solution
Motor does not rotate	<ol style="list-style-type: none"> 1. 24V power not connected or reversed. 2. ENA has no valid enable signal. 3. Motor wiring error/open circuit. 4. STP signal abnormal. 	<ol style="list-style-type: none"> 1. Check power wiring. 2. Confirm ENA level. 3. Verify coil wiring. 4. Check controller output.
Motor jitters / loses steps	<ol style="list-style-type: none"> 1. Rotation speed too high. 2. Load too large. 3. Acceleration time too short when switching direction at high speed. 	<ol style="list-style-type: none"> 1. Adjust input voltage. 2. Reduce load / replace with higher torque motor. 3. Stop voltage output before switching direction.
Motor direction abnormal	<ol style="list-style-type: none"> 1. DIR level reversed. 2. A/B phase coils reversed. 	<ol style="list-style-type: none"> 1. Adjust DIR logic. 2. Swap A+/A- or B+/B-.
Driver overheats severely	<ol style="list-style-type: none"> 1. Drive current set too high. 2. Poor heat dissipation. 3. Motor short circuit. 	<ol style="list-style-type: none"> 1. Reduce running current in software. 2. Strengthen heat dissipation. 3. Check motor coils.